

LOU MARTIN &  
ASSOC INC

2107 DANBURY DRIVE  
SAN ANTONIO, TEXAS 78217

PHONE: (210) 930-8181  
FAX: (210) 930-8184

**COMPONENT MAINTENANCE MANUAL  
WITH  
ILLUSTRATED PARTS LIST**

**Piaggio 180 Mechanical Window Shade Assembly**

First Issue: MAY 08/06

25-23-11

MAY 08/06

**Lou Martin & Assoc., Inc.**  
Component Maintenance Manual

**Lou Martin & Assoc., Inc.**  
Component Maintenance Manual

Record of Revisions

Rev. No.	Issue Date	Date Inserted	By	Rev. No.	Issue Date	Date Inserted	By
IR	08MAY06	08MAY06	C.M.				

**Lou Martin & Assoc., Inc.**  
Component Maintenance Manual



**Lou Martin & Assoc., Inc.**  
Component Maintenance Manual



**Lou Martin & Assoc., Inc.**  
Component Maintenance Manual

TABLE OF CONTENTS

	Page
RECORD OF REVISIONS	1
RECORD OF TEMPORARY REVISIONS	1
SERVICE BULLETIN LIST	1
TABLE OF CONTENTS	1
LIST OF EFFECTIVE PAGES	1
INTRODUCTION	1
1. General	1
2. Layout of manual	1
3. Revision of the document	2
4. Certification of operations	3
5. WARNINGS-CAUTIONS-NOTES	3
6. List of Abbreviations	4
DESCRIPTION AND OPERATION	1
1. Description	1
2. Technical Data	2
TESTING AND FAULT ISOLATION	1001
1. Testing	1001
2. Fault Isolation	1002
SCHEMATIC AND WIRING DIAGRAMS	NOT APPLICABLE
UNINSTALLING WINDOW ASSY.	3001
1. General	3001
2. Job set-up information	3001
3. Preliminary Steps	3001
4. Decorative window removal	3002
DISASSEMBLY	4001
1. General	4001
2. Job set-up information	4001
3. Preliminary Steps	4001
4. Inner lens removal	4002
5. Blind mod. assy. removal	4002
CLEANING	5001
1. General	5001
2. Job set-up information	5001
3. Procedure	5002

TABLE OF CONTENTS

PAGE 1

MAY 08/06



**Lou Martin & Assoc., Inc.**  
Component Maintenance Manual

INSPECTION/CHECK	6001
1. General	6001
2. Replacement of Parts	6001
REPLACEMENT & REPAIR	7001
1. General	7001
2. Job set-up information	7001
3. Replacement procedure for broken shade string	7003
4. Replacement procedure for a damaged inner lens	7004
ASSEMBLY	8001
1. General	8001
2. Job set-up information	8001
3. Blind mod. Reattachment	8002
4. Inner Lens reattachment	8003
FITS AND CLEARANCES	9001
1. General	9001
2. Clearances	9001
SPECIAL TOOLS, FIXTURES, EQUIPMENT	10001
1. Special tools, fixtures and equipments	10001
STORAGE	11001
1. General	11001
ILLUSTRATED PARTS LIST	INTRO IPL 1
1. Introduction	INTRO IPL 1
2. How to use the Illustrated Parts List	INTRO IPL 4
3. Alphanumerical Index	ALPHANUMERICAL INDEX
DETAILED PARTS LIST	12001

TABLE OF CONTENTS  
PAGE 2  
MAY 08/06

**Lou Martin & Assoc., Inc.**  
Component Maintenance Manual

LIST OF EFFECTIVE PAGES

SUBJECT	PAGE	DATE	SUBJECT	PAGE	DATE
TITLE PAGE	1	MAY 08/06	UNINSTALLING	3001	MAY 08/06
			WINDOW ASSY.	3002	MAY 08/06
RECORD OF REVISIONS	1	MAY 08/06			
			DISASSEMBLY	4001	MAY 08/06
RECORD OF TEMPORARY REVISIONS	1	MAY 08/06		4002	MAY 08/06
			CLEANING	5001	MAY 08/06
				5002	MAY 08/06
SERVICE BULLETIN LILST	1	MAY 08/06		5003	MAY 08/06
				5004	BLANK
TABLE OF CONTENTS	1	MAY 08/06	INSPECTION/	6001	MAY 08/06
	2	MAY 08/06	CHECK	6002	BLANK
LIST OF EFFECTIVE PAGES	1	MAY 08/06	REPLACEMENT &	7001	MAY 08/06
	2	MAY 08/06	REPAIR	7002	MAY 08/06
				7003	MAY 08/06
INTRODUCTION	1	MAY 08/06			
	2	MAY 08/06	ASSEMBLY	8001	MAY 08/06
	3	MAY 08/06		8002	MAY 08/06
	4	MAY 08/06		8003	MAY 08/06
	5	BLANK			
			FITS AND	9001	MAY 08/06
			CLEARANCES	9002	BLANK
DESCRIPTION AND OPERATION	1	MAY 08/06	SPECIAL TOOLS,	10001	MAY 08/06
	2	MAY 08/06	FIXTURES, AND		
	3	MAY 08/06	EQUIPMENT		
	4	MAY 08/06			
TESTING AND FAULT	1001	MAY 08/06	STORAGE	10001	MAY 08/06
	1002	MAY 08/06		10002	BLANK
	1003	MAY 08/06			
	1004	BLANK			

LIST OF EFFECTIVE PAGES  
PAGE 1  
MAY 08/06

**Lou Martin & Assoc., Inc.**  
Component Maintenance Manual

LIST OF EFFECTIVE PAGES

SUBJECT	PAGE	DATE	SUBJECT	PAGE	DATE
ILLUSTRATED PARTS LIST	INTRO IPL 1	MAY 08/06			
	INTRO IPL 2	MAY 08/06			
	INTRO IPL 3	MAY 08/06			
	INTRO IPL 4	MAY 08/06			
	INTRO IPL 5	MAY 08/06			
	INTRO IPL 6	BLANK			
ALPHANUMERICAL INDEX		1			MAY 08/06
DETAILED PARTS LIST	120001-0	MAY 08/06			
	120001-1	MAY 08/06			
	120002-0	MAY 08/06			
	120002-1	MAY 08/06			

**Lou Martin & Assoc., Inc.**  
Component Maintenance Manual

Introduction

TASK 25-23-11-990-801

1. General

- A. This document writing follows the directives of the “A.T.A Specification No. 100” updating N° 36. The instructions in this manual give the information necessary to do maintenance functions ranging from simple checks and replacement to complete shop type repair for the equipment, manufactured and supported by:

Lou Martin & Assoc., Inc. 2107 Danbury Drive San Antonio, TX. 78217 USA Tel.: (210) 930-8181 – Fax: (210) 930-8184
---

- B. This document is applicable to the following equipment:

Piaggio P180 Mechanical Window Shade Assy.	P180-113M002
	P180-113M004
	P180-113M006

TASK 25-23-11-990-802

2. Layout of manual

- A. This manual contains a general description and operation followed by data for maintenance, repair, disassembly and assembly of the equipment. This is followed by an illustrated parts list (IPL), which gives detailed information.
- B. The manual is divided into separate sections:
- (1) Title Page
  - (2) Record of Revisions
  - (3) Table of Contents
  - (4) Introduction
  - (5) Procedures and IPL Sections

INTRO  
PAGE 1  
MAY 08/06

**Lou Martin & Assoc., Inc.**  
Component Maintenance Manual

- C. This manual will be updated as required by revisions: Service Bulletins may be issued separately. Their effect on this manual will be made evident by reissue of the appropriate list of Service Bulletins.

TASK 25-23-11-990-803

3. Revision of the document

- A. Two types of revisions of the manual are used to follow the evolution of this equipment/

(1) Normal revision

- (a) Normal revisions are periodically issued.
- (b) They are printed on white paper
- (c) A List of Revisions gives a better follow-up of these revisions.
- (d) The changes in the text are shown by a vertical line drawn in the left margin.

(2) Temporary revision

- (a) Temporary revisions can be issued in advance of the normal revision.
- (b) They are printed on yellow paper.
- (c) A List of Temporary Revisions gives their follow-up.
- (d) A letter comes with these temporary revisions to give all the necessary information about the insertion of these revisions.

INTRO  
PAGE 2  
MAY 08/06

**Lou Martin & Assoc., Inc.**  
Component Maintenance Manual

- (3) General rules for the insertion of temporary revisions
  - (a) A yellow page (with a higher sequential number) can replace a yellow page.
  - (b) A yellow page cannot replace a white page.

TASK 25-23-11-990-804

4. Certification of operation

- A. The maintenance operations described in the present COMPONENT MAINTENANCE MANUAL have been checked in the manufacturer's workshop by observing the disassembly, assembly, testing, and trouble-shooting instructions detailed in this document.

TASK 25-23-11-990-805

5. WARNINGS-CAUTIONS-NOTES

- A. Special adjuncts to the text are expressed by the following headings:

WARNING : CALL ATTENTION FOR THE USE OF MATERIALS, PROCESSES, METHODS, PROCEDURES OR TOLERANCES WHICH MUST BE ADHERED TO CAREFULLY IN ORDER TO AVOID ANY INJURY.

CAUTION: CALL ATTENTION TO METHODS AND PROCEDURES, WHICH MUST BE ADHERED TO IN ORDER TO AVOID DAMAGE TO EQUIPMENT.

NOTE: Call attention to methods, which make the procedures easier.

INTRO  
PAGE 3  
MAY 08/06

**Lou Martin & Assoc., Inc.**  
Component Maintenance Manual

TASK 25-23-11-990-806

6. List of Abbreviations

ASSY	: ASSEMBLY
ATA	: AIR TRANSPORT ASSOCIATION OF AMERICA
FAA	: FEDERAL AVIATION ADMINISTRATION
FAR	: FEDERAL AVIATION REGULATION
IPL	: ILLUSTRATED PARTS LIST
LB.	: POUND
MS	: MILITARY STANDARD
NAS	: NATIONAL AEROSPACE STANDARD
REV	: REVISION
SB	: SERVICE BULLETINS
TR	: TEMPORARY REVISION

INTRO  
PAGE 4  
MAY 08/06

25-23-11

**Lou Martin & Assoc., Inc.**  
Component Maintenance Manual

PAGE INTENTIONALLY LEFT BLANK

INTRO  
PAGE 5  
MAY 08/06

25-23-11



**Lou Martin & Assoc., Inc.**  
Component Maintenance Manual

TASK 25-23-11-870-806

DESCRIPTION AND OPERATION

1. Description

A. General

Basically, the decorative window shade assy. is made of a metal frame assy, blind assy., inner & outer lenses.

For attachment, refer to completion center for information.

B. Composition

Basic Cabin Window - (See FIGURE 1 / GRAPHIC 25-23-11-991-001 next page)

False Window - (See FIGURE 2 / GRAPHIC 25-23-11-991-002 page 3)

C. Window location layout

(See FIGURE 3 / GRAPHIC 25-23-11-991-003 page 4)

**Lou Martin & Assoc., Inc.**  
Component Maintenance Manual

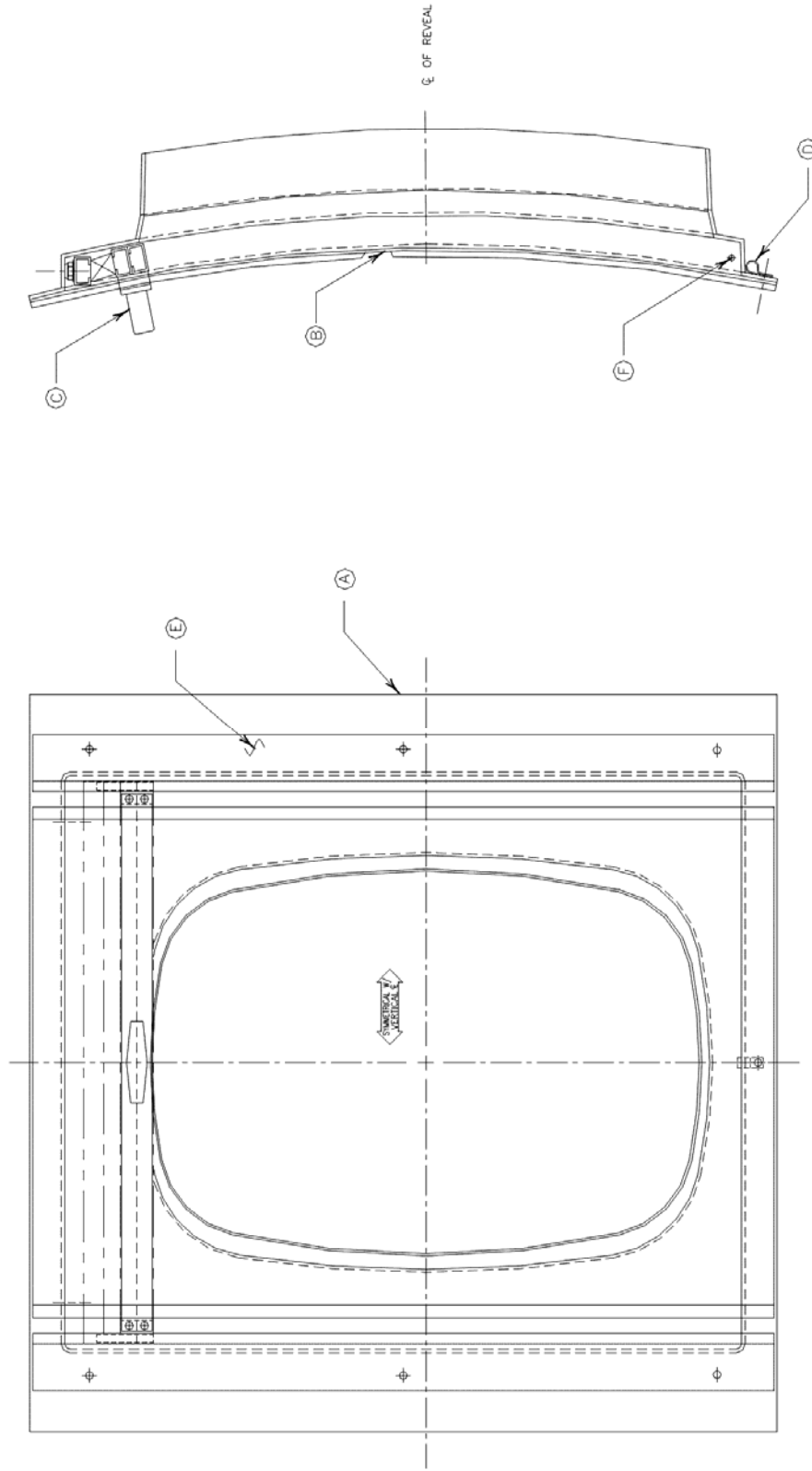

P/N:	P180-113M001-1
P/N:	P180-113M002-59
P/N:	P180-113M002-51
P/N:	3254T2
P/N:	P180-113M002-5
P/N:	0430000

**LEGEND:**

A	WINDOW REVEAL
B	INNER LENS
C	BLIND MOD. ASSY.
D	LOOP CLAMP
E	SLIDE TRACK
F	EYELET

**BASIC PIAGGIO WINDOW BREAKDOWN**

TYPICAL CABIN WINDOW SHOWN

FIGURE 1 / GRAPHIC 25-23-11-991-001

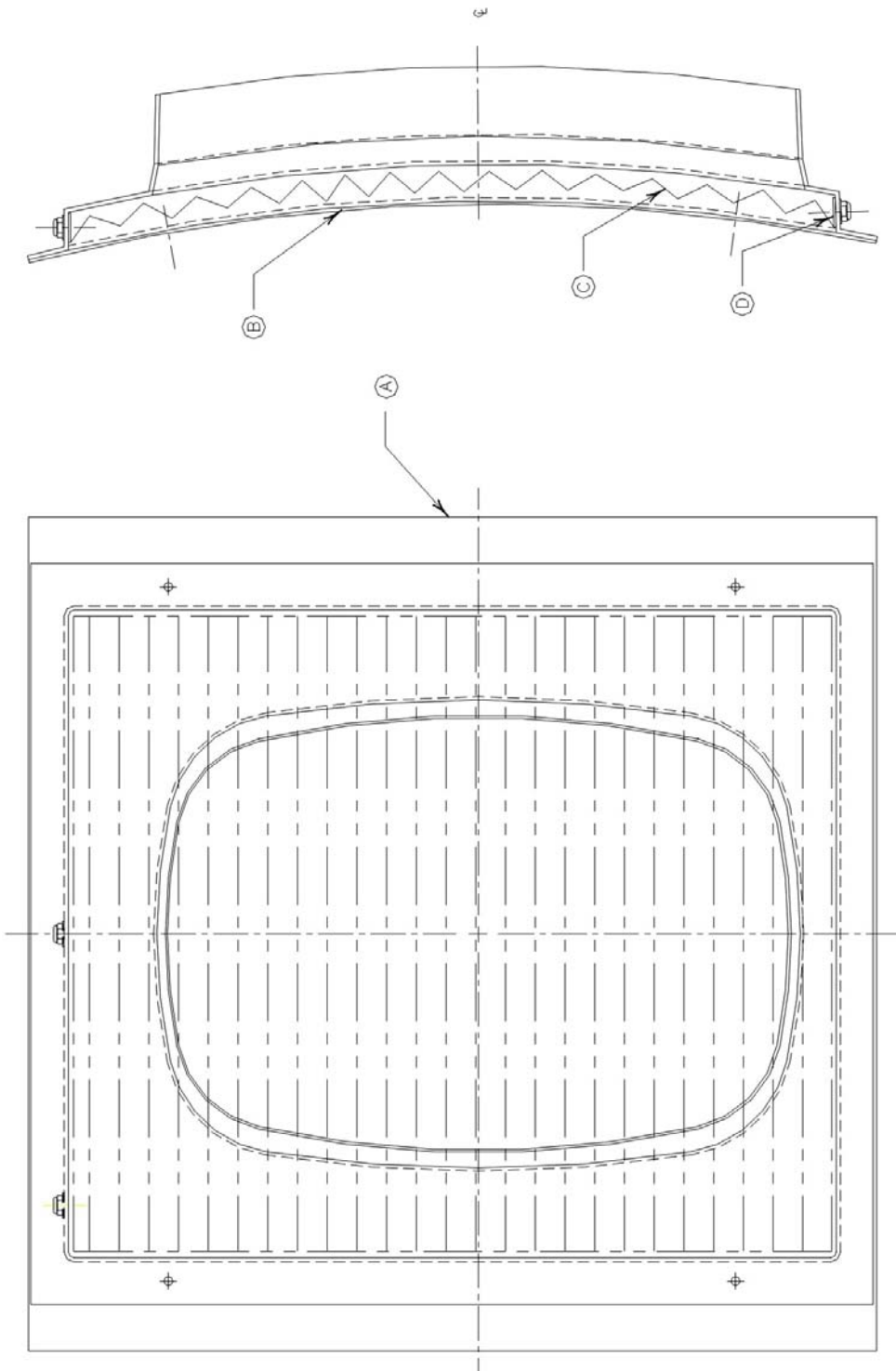
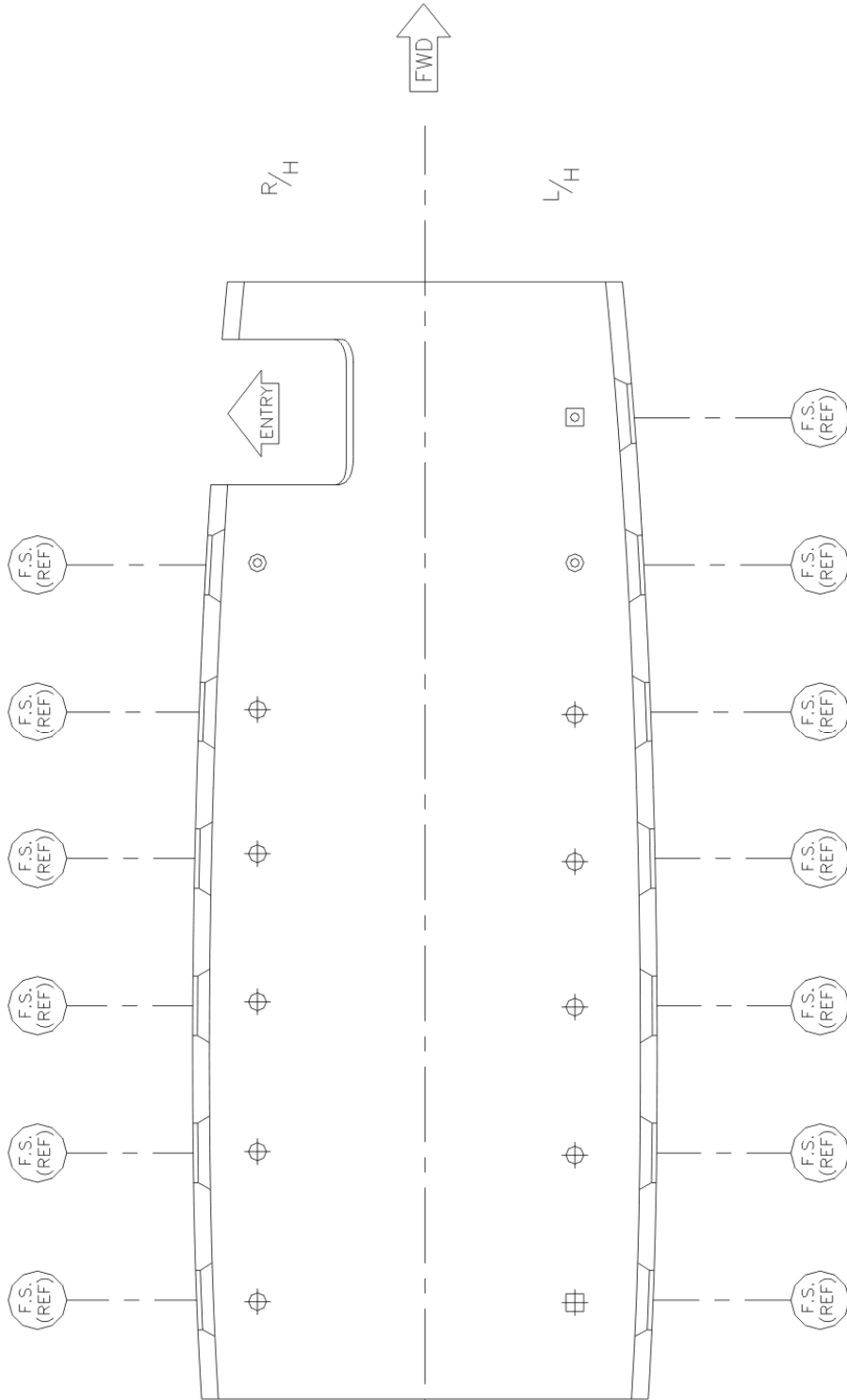

FIGURE 2 / GRAPHIC 25-23-11-991-002

**FALSE PIAGGIO WINDOW BREAKDOWN**

**LEGEND:**

A	WINDOW REVEAL	P180-113M001-1
B	INNER LENS	P180-113M004-55
C	SHADE FABRIC	P180-113M004-51
D	SPACER	P180-113M004-53



**CABIN WINDOW FLOORPLAN**

- ⊕ TYPICAL CABIN WINDOW
- ⊙ MODIFIED CABIN WINDOW
- ⊞ FALSE CABIN WINDOW
- ⊠ E-HATCH WINDOW

FIGURE 3 / GRAPHIC 25-23-11-991-003

**Lou Martin & Assoc., Inc.**  
Component Maintenance Manual

TESTING AND FAULT ISOLATION

TASK 25-23-11-700-806

1. Testing

A. General

- (1) The tests check the different adjustments, components and mechanisms of the window shade unit.
- (2) The defective parts must be repaired in workshops or can be replaced by serviceable parts.

B. Job set-up information

- (1) Tools, fixtures, equipment and materials

NOTE: Refer to “SPECIAL TOOLS, FIXTURE AND EQUIPMENTS”  
for full details on the items used.

C. Procedure

- (1) Make sure the shade unit operates with the desired tension

**Lou Martin & Assoc., Inc.**  
Component Maintenance Manual

TASK 25-23-11-700-802

2. Fault isolation

- A. Faults you can find during the operations are given here under together with their probable causes and their corrective actions.
- B. After the necessary corrective action is done, do an inspection of the window unit to make sure that the fault is corrected.
- C. Mechanical fault isolation

TROUBLE	POSSIBLE CAUSE	CORRECTION
<b>SHADE ASSY.</b>		
Shade assy. does not operate with the desired tension	Incorrect tension	Adjust tension as required to add/release tension See Figure 4/ graphic 25-23-11-991-004
<b>DECORATIVE HANDLE</b>		
Handle is loose	Screw holding handle in place are loose	Tighten attachment screw
<b>LEXAN LENSES</b>		
Lens is loose	Screw holding lens in place are loose	Tighten attachment screw

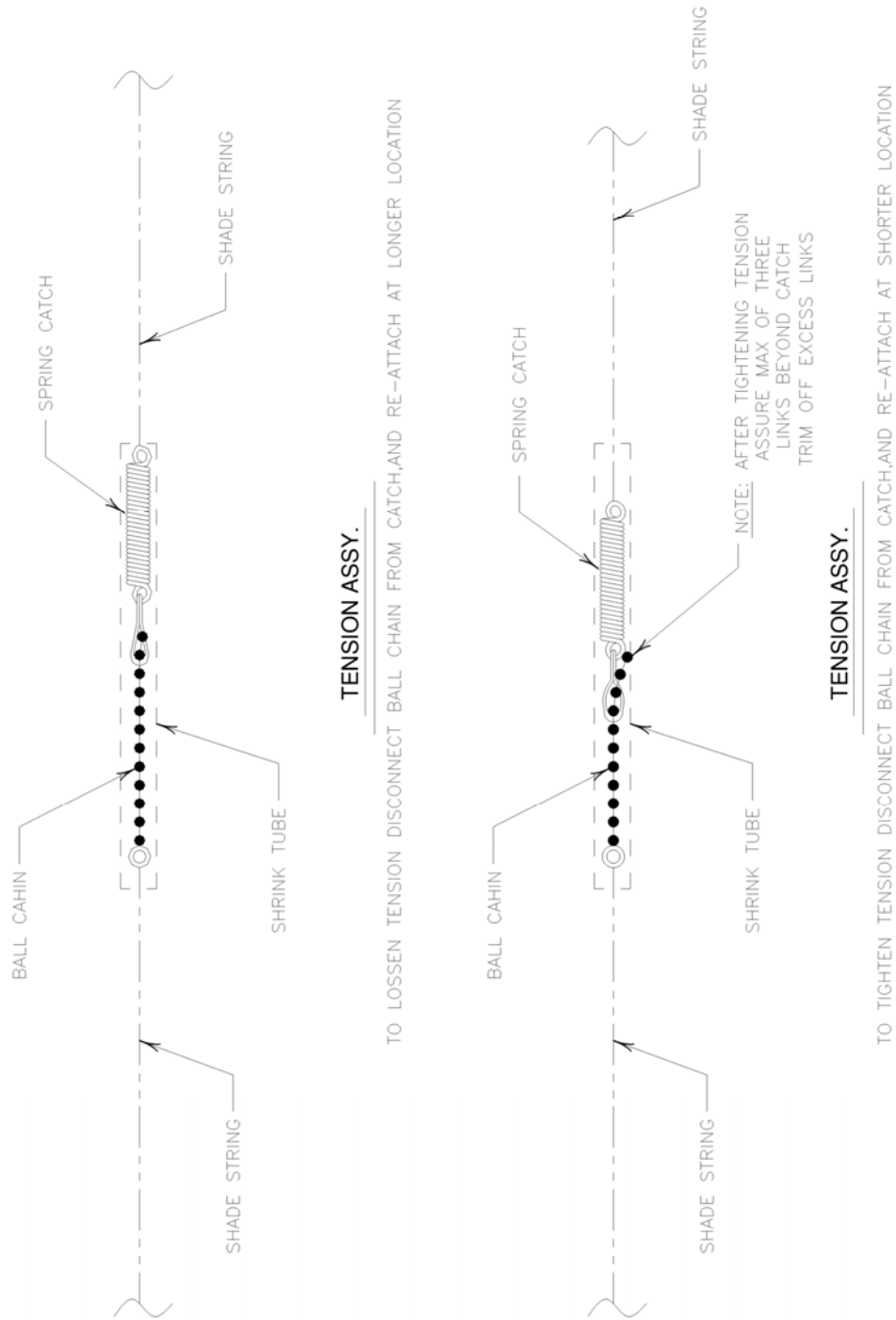

FIGURE 4/ GRAPHIC 25-23-11-991-004

**Lou Martin & Assoc., Inc.**  
Component Maintenance Manual

PAGE INTENTIONALLY LEFT BLANK

PAGE 1004  
MAY 08/06

25-23-11



**Lou Martin & Assoc., Inc.**  
Component Maintenance Manual

UNINSTALLING WINDOW SHADE ASSY.

TASK 25-23-11-000-801

1. General

- A. The overhaul instructions contained in this manual are usually implemented in mechanical overhaul workshops.
- B. Avoid removing identification plates, unless manufacturer authorization.
- C. Assure window unit inner and outer lens, and any decorative plated parts are protected at all times when removed from the aircraft.
- D. When removing and transporting the window unit assure the shade is in the up position.

TASK 25-23-11-940-806

2. Job set-up information

- A. Tools, Fixtures, equipment and materials  
None.

TASK 25-23-11-000-802

3. Preliminary Steps

- A. Before the uninstalling, make note of the window assy. location for efficient re-installation and to prevent errors.

**Lou Martin & Assoc., Inc.**  
Component Maintenance Manual

TASK 25-23-11-040-806

6. Decorative window removal:

- A. Prior to removing window shade assure shade assy. is in up position
- B. Refer to P180-113M007 for window shade removal.

- 501 For Typical cabin window
- 503 For False window
- 505 For Modified cabin window
- 507 For E-Hatch window

NOTE: Assure inner lens and handle are protected at all times

**Lou Martin & Assoc., Inc.**  
Component Maintenance Manual

DISASSEMBLY

TASK 25-23-11-000-802

1. General

- A. The overhaul instructions contained in this manual are usually implemented in mechanical overhaul workshops.
- B. Avoid removing identification plates, unless manufacturer authorization.
- C. Only disassemble what is necessary to do the repairs or to replace defective part(s).
- D. When applying the following instructions, never disassemble those components, which have been proved to be in good condition after inspection unless their disassembly is necessary to get access to the defective part.
- E. All the parts must be identified before the disassembly in order to prevent the error and to make the reassembly easier.
- F. For the identification of damage or functional failure refer to:

“CHECKING”

TASK 25-23-11-940-802

2. Job set-up information

- A. Tools, fixtures, equipment and materials  
None.

TASK 25-23-11-000-803

3. Preliminary Steps

- A. Before the disassembly, put marks on all the parts to help the reassembly and to prevent errors.

**Lou Martin & Assoc., Inc.**  
Component Maintenance Manual

TASK 25-23-11-040-801

5. Inner lens removal

- A. Remove screws holding the inner lens in place.
- B. Remove inner lens, protect both sides from damage.

TASK 25-23-11-040-802

6. Blind mod. assy. removal

- A. Remove screw & stop nut holding tension spring and detach chain & spring.
- B. Untie string from spring and ball catch; if string can not be untied it is permissible to cut string. However, cutting string may result in string being too short to achieve proper tension after service. Lou Martin & Assoc., Inc. recommends ordering a new string at proper length to ensure proper tension and operation after service. See REPLACEMENT & REPAIR, section 4 for string replacement.
- C. To remove the lower rail assy. remove slide tracks from both sides of reveal. Slide shade glides off end of glide, this will free lower rail.
- D. Upper blind mod. is attached with two or three screws and stop nuts depending on size, remove stop nuts and top of blind will be free from with-in reveal.

**Lou Martin & Assoc., Inc.**  
Component Maintenance Manual

CLEANING

TASK 25-23-11-100-806

1. General

- A. A full cleaning is necessary before each accurate inspection to find the correct location and the extent of the damage.
- B. Cleaning removes all the remaining particles, which can have an unwanted effect on the performance of the equipment. It also helps the possible repair.

TASK 25-23-11-940-803

2. Job set-up information

- A. Tools, Fixtures, equipment and materials

NOTE: Refer to “SPECIAL TOOLS, FIXTURES, EQUIPMENT AND MATERIALS” for full details on the items used.

---

REFERANCE	QTY	NAME
#PC-10	AR	NOVUS PLASITC POLISH
BRILLIANIZE	AR	CLEANER & POLISH
SPRAYWAY	AR	VINAL LEATHER CLEANER
39139 (Prepsol)	AR	CLEANER FOR NON-FABRIC PARTS

**Lou Martin & Assoc., Inc.**  
Component Maintenance Manual

TASK 25-23-11-100-802

3. Procedure

A. How to use Novus Plastic Polish No. 1

Remove surface dust with soft cloth. Shake bottle contents and apply a light mist. Spread evenly and buff with a clean, soft, lint-free cloth.

B. How to use BRILLIANIZE Cleaner & Polish

Shake contents firmly and apply evenly to any hard, shiny, non-absorbent surface at room temperature. Rub gently. Before surface dries, polish with a dry lint-free cloth or non-damaging material, until the surface feels “as smooth as ice”.



FIGURE 5/ GRAPHIC 25-23-11-991-005

**Lou Martin & Assoc., Inc.**  
Component Maintenance Manual

C. Shade fabric

Lou Martin easy-glide shade systems utilize a metallized fabric, which is inherently anti-static. They actually repel dust and seldom require cleaning. An occasional light sweep of a vacuum is all that should be needed.

In the event of a mishap, Lou Martin easy-glide shades may be cleaned with a mild detergent and water. However, water spotting can occur. If a detergent is required, we suggest a mild detergent such as woolite.

Do not use ammonia cleaners near the Lou Martin easy-glide shade. Ammonia cleaners will damage the shade.

**Lou Martin & Assoc., Inc.**  
Component Maintenance Manual

PAGE INTENTIONALLY LEFT BLANK

PAGE 5004  
MAY 08/06

25-23-11



**Lou Martin & Assoc., Inc.**  
Component Maintenance Manual

INSPECTION/CHECK

TASK 25-23-11-200-806

1. General

- A. Checks are to be done at the customer's discretion. Write all the damage detected, in some condition, the cause and/or the source. Immediately repair all the damage found.
- B. Visually check all hardware, detail parts and assemblies for the following criteria:
  - (1) Wear, tears, fraying of the shade & decorative mask fabric.
  - (2) Correct attachment and condition of the Velcro tapes
  - (3) Tightening of the screws and nuts
  - (4) Condition of the Inner and Outer Lenses for scratches, cracks or spots.
  - (5) Condition of the reveal for scratches, chipping or fading of the paint.
  - (6) Condition of the plated handle assy. for scratches
- C. Do a careful check of all the parts for corrosion, distortion, incipient cracks, cracks, dents, nicks, scores, stripped threads, excessive wear, etc. which can damage the performance of the equipment and give it an unsatisfactory condition.

TASK 25-23-11-200-802

2. Replacement of Parts

After the replacement of an item, write a list of the defective parts you must replace and a list of the parts on which a repair or a new production is necessary.

**Lou Martin & Assoc., Inc.**  
Component Maintenance Manual

PAGE INTENTIONALLY LEFT BLANK

PAGE 6002  
MAY 08/06

25-23-11

**Lou Martin & Assoc., Inc.**  
Component Maintenance Manual

REPLACEMENT & REPAIR

TASK 25-23-11-300-801

1. General

- A. The procedures given in this chapter are general repair procedures and are not applicable to the riveted or welded parts. The manufacturer must repair the riveted or welded junctions, which are damaged.

TASK 25-23-11-940-804

2. Job set-up information

- A. Tools, fixtures, equipment and materials
- B. It is recommended that the completion center contact Lou Martin & Assoc., Inc. for replacement parts to insure quality and operation

NOTE: Assure window unit lenses, plated parts, decorative mask parts are protected at all times when work is being done.

(1) Repair materials

---

REFERANCE	QTY	NAME
4945	AR	3M Acrylic foam tape
FMR-604 (.06 Thk.)	AR	Replacement inner lens
8-MIL CORD (WHITE)	AR	Replacement shade string
MS21044-N08	AR	Replacement stop nut
MS21044-N06	AR	Replacement stop nut
MS24693S-632	AR	Replacement screw
MS24693S-832	AR	Replacement screw

**Lou Martin & Assoc., Inc.**  
Component Maintenance Manual

TASK 25-23-11-350-802

4. Replacement procedure for broken shade string

- A. For removal of blind mod. See “DISASSAMBL Y” section 5
- B. Remove broken string and replace with new string.
- C. Tie upper left screw at mid way thru string and run string thru shade assy. (See FIGURE 6/ GRAPHIC 25-23-05-991-006)
- D. Reinsert glides into slide track and reattach to reveal.
- E. Reattach upper blind mod. assy. (See “ASSEMBLY”, section 5)

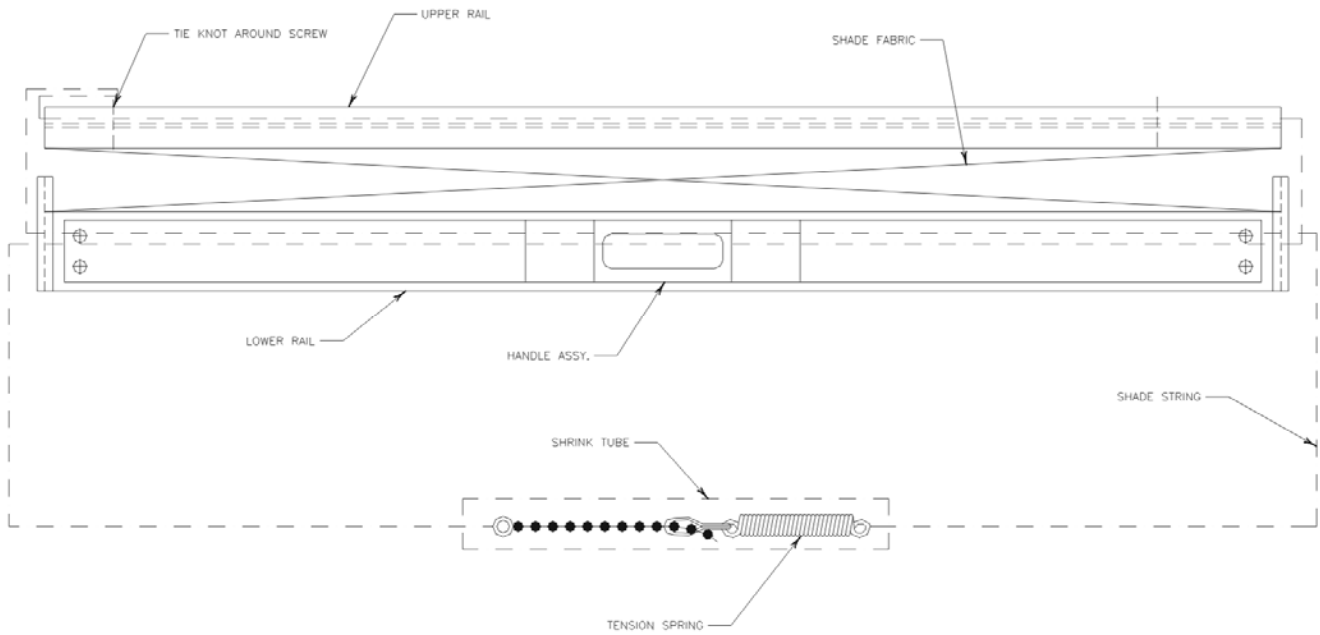

FIGURE 6/ GRAPHIC 25-23-11-991-006

**Lou Martin & Assoc., Inc.**  
Component Maintenance Manual

TASK 25-23-11-350-803

5. Replacement procedure for a damaged inner lens

- A. Mark both sides of inner lens on reveal to assure replacement inner lens is properly located during reassembly.
- B. Remove inner lens from window assy. (See “DISASSEMBLY”, section 5)
- C. Trim replacement inner lens to size, ref chart below for proper sizing, or match size w/ damaged inner lens.
- D. Before attaching new lens decide which side of lens will be facing inboard. Peel back this side’s protective film. Bond .30 x .06 thk. Self-adh. Loop side velcro to the edge of the inner lens. Note: Sand lexan surface before applying velcro.
- E. Before attaching new lens peel off protective film from the outboard side of lens. Note: Before clamping, use a static blow-off gun to eliminate dust attraction on both sides of lens
- F. Clamp replacement inner lens to window assy. (Velcro facing inboard), assure lens follows window reveal’s contour. Note: it will help if the lower surface of lens is clamped first then force the lens to follow reveals contour then clamp upper lens surface. Test shade up & down to check for tension. Loose lens will ease the tension on the shade, if not refer to “Testing & Fault Isolation”.
- G. Attach new inner lens to window assy. Match drill lens with existing hole locations. Then remove clamps. (See “ASSEMBLY”, section 4)

**Inner lens sizes**

Typical window:	12.40 x 18.40 x .06 Thk.
Modified window:	11.50 x 18.00 x .06 Thk.
False window:	16.00 x 18.40 x .06 Thk.
E-hatch window:	11.50 x 18.00 x .06 Thk.

PAGE 7003  
MAY 08/06

**Lou Martin & Assoc., Inc.**  
Component Maintenance Manual

ASSEMBLY

TASK 25-23-11-400-801

1. General

- A. Before the assembly, make sure that the CLEANING, the CHECK and the REPAIR procedures of all parts are done.
- B. Where it is possible, it is recommended to use new parts and genuine approved parts.

TASK 25-23-11-940-804

2. Job set-up information

- A. Tools, Fixtures, equipment and materials

NOTE: Refer to SPECIAL TOOLS, FIXTURES, EQUIPMENT AND MATERIALS for full details on the items used.

---

REFERENCE	QTY	NAME
4945	AR	3M Acrylic foam tape
FMR-604 (.06 Thk.)	AR	Replacement inner lens
MS21054-N06	AR	Replacement stop nut (Regular)
MS21055-N06	AR	Replacement stop nut (Thin)
MS63050-06	AR	Replacement washer
MS24693S-632	AR	Replacement screw
MS27039S-632	AR	Replacement screw
AN526-630-R10	AR	Replacement screw
MS35207-832	AR	Replacement screw

**Lou Martin & Assoc., Inc.**  
Component Maintenance Manual

TASK 25-23-11-440-801

3. Blind mod. Reattachment

- A. Reattach upper blind mod. to the reveal by inserting the upper rail's screws thru the two existing holes in the top of the reveal cavity, and secure with MS21054-N05 or MS21054-N06 stop nuts. (See FIGURE 7/ GRAPHIC 25-23-11-991-007)

NOTE: Assure a proper attachment with a min. two threads protruding thru nylon nut.

- B. Reinsert the lower rail glides into their slide tracks and reattach slide tracks to the reveal using MS24693S-632 screw and MS21054.N06 stop nut (2 places per track)
- C. Rethread shade string thru eyelets at bottom of reveal and reattach tension spring
- D. Resecure tension spring with existing loop clamp using MS24693S-632 screw & MS21054-N06 stop nut.

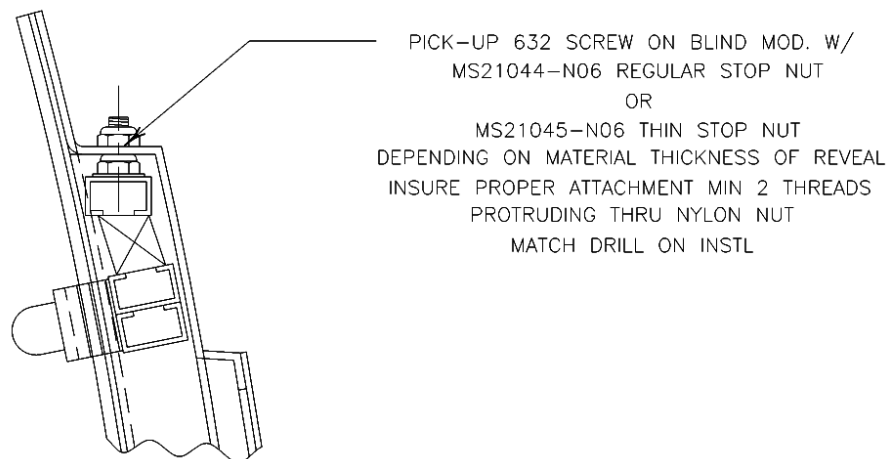

FIGURE 7/ GRAPHIC 25-23-11-991-007

**Lou Martin & Assoc., Inc.**  
Component Maintenance Manual

TASK 25-23-11-440-802

4. Inner lens reattachment

- A. Reattach inner lens with AN507-832 screw and AN365-832A stop nut (4 plc's).

NOTE: Remove protective film from side that will face window reveal.

- B. Remove protective film from inboard side of lens after attachment.



**Lou Martin & Assoc., Inc.**  
Component Maintenance Manual

FITS AND CLEARANCES

TASK 25-23-11-820-801

1. General

- A. The listed clearances are to insure the window is properly installed into the aircraft

TASK 25-23-11-820-802

2. Clearances

- A. Assure a min. clearance of .063 in. (1.59 cm) between the window shade assy. and existing structure.
- B. Assure a min. clearance of .13 in. (3.18 cm) between the window assy's outer lens and the inboard side of the aircraft's existing pressure lens.
- C. Assure a min. clearance of .04 in. (1.02 cm) between each decorative mask fwd & aft in the aircraft.

**Lou Martin & Assoc., Inc.**  
Component Maintenance Manual

PAGE INTENTIONALLY LEFT BLANK

PAGE 9002  
MAY 08/06

25-23-11

**Lou Martin & Assoc., Inc.**  
Component Maintenance Manual

SPECIAL TOOLS, FIXTURES, EQUIPMENT

TASK 25-23-11-940-805

1. Special tools, fixtures and equipments

No special tools, fixtures and equipment are necessary for the maintenance or the overhaul to be performed on the standard equipment.

Standard tools are used for these operations.

**Lou Martin & Assoc., Inc.**  
Component Maintenance Manual

STORAGE

TASK 25-23-11-940-806

1. General

- A. When any of the window assay's need to be removed from the aircraft, Lou Martin & Assoc., Inc. recommends to stow the shade is in the up position.
- B. Store in a sheltered, ventilated place with normal hygrometric degree (70%)
- C. Cover the window unit with large clean plastic bags or equivalent to protect it from dust and other airborne particles.
- D. On the outside of the bag or cover add a tag with its location in the aircraft for tracking purposes and quicker reinstallation in the aircraft.

**Lou Martin & Assoc., Inc.**  
Component Maintenance Manual

PAGE INTENTIONALLY LEFT BLANK

PAGE 11002  
MAY 08/06

25-23-11

**Lou Martin & Assoc., Inc.**  
Component Maintenance Manual

ILLUSTRATED PARTS LIST

TASK 25-23-11-950-806

1. Introduction

A. General

- (1) The Illustrated Parts List (IPL) intends to show the details of the equipment and permits easy provisioning of the spares necessary for the maintenance of this equipment.

B. Use of the illustrated parts list

- (1) “Introduction” section

The introduction contains all explanatory information for the individual sections necessary for the use of this IPL.

- (2) “Illustrated Parts List” section

The detailed parts list gives the list and the illustrations of parts making up the considered assembly. The different columns of the parts list pages are organized as follows:

- 1<sup>st</sup> column: Figure and item number
- 2<sup>nd</sup> column: Manufacturer’s part number
- 3<sup>rd</sup> column: Airline part number (not used)
- 4<sup>th</sup> column: Indenture
- 5<sup>th</sup> column: Designation
- 6<sup>th</sup> column: Usage from to
- 7<sup>th</sup> column: Quantity per Assembly

- (a) Figure and item number

1 Each illustration receives a figure number starting at 06 and carrying on in sequence.

2 Each illustration can be divided up into several folios

3 When it is necessary to add figures, alphabetic indexes are added to the original figure, from A to Z, except I and O

INTRO IPL  
PAGE 1  
MAY 08/06

**Lou Martin & Assoc., Inc.**  
Component Maintenance Manual

- 4 An item number is attributed to each part mentioned in the detailed parts list. Numbers start at 006A up to 999A per sequence of 10 by 10 or else in order to insert additional items.
- 5 Alternative parts have the same item as the initial part and are indexed.
- 6 To follow the evolution of the standard of parts or assemblies modification, items are indexed from B to Z, except I and O.
- 7 Non-illustrated items are identified by a dash placed in front of the item.

(b) Manufacturer's part number

This column indicates the original manufacturer's part number or the part manufacturer.

(c) Airline part number

This column is left blank; it is reserved for the airline.

(d) Indenture

The designation is presented according to indentations indicating as follows the relation between the different components:

1 Assembly

2 Sub-assemblies

2 Attaching parts of the sub-assembly

3 Constitutive parts of the sub sub-assembly

3 Attaching parts of the sub sub-assembly

4 Constitutive parts of the sub subassembly  
Etc.

INTRO IPL  
PAGE 2  
MAY 08/06

**Lou Martin & Assoc., Inc.**  
Component Maintenance Manual

(e) Designation

The designation of the item can be followed by:

- The CAGE manufacturer's code,
- Cross-references indicating numbers, figures, items where this very item is illustrated.

(f) Usage from to

The interchangeability relation of constitutive parts according to the higher assembly is identified by the item number.

This code is only valid for the assembly dealt with in the corresponding figure.

Example:

FIG-ITEM	PART MUMBER	AIRLINE PART NUMBER	I N D	NOMENCLATURE	USAGE FROM TO	UNITS PER ASSY.
- 1A	PN1		1	ASSEMBLY 1		RF
- 1B	PN2		1	ASSEMBLY 2		RF
- 1C	PN3		1	ASSEMBLY 3		RF
10A	SPN1		2	SUB-ASSEMBLY 1	1AC	1
10B	SNP2		2	SUB-ASSEMBLY 2	1B	1
20A	SSNP1		3	SUB SUB-ASSEMBLY 1	10A	1
20B	SSPN2		3	SUB SUB-ASSEMBLY 2	10B	1
30A	SPN3		2	SUB-ASSEMBLY 3		1



**Lou Martin & Assoc., Inc.**  
Component Maintenance Manual

(g) Quantity per assy.

This column gives the number of parts required for an immediately higher assembly.

If a same assembly or a same part appears in several figures, the quantity is only given in the first parts list; the RF abbreviation appears in the following parts list.

If the quantity of a component is to be established as required (EX. seal, etc.) the quantity is replaced by the term AR (as required)

(2) How to use the Illustrated Parts List

(a) When the part number is known:

- 1 Turn to the numerical index and locate the part number.
- 2 The figure and item number on the illustration where the part appears are listed in the column to the right of the part number.
- 3 The corresponding item number in the accompanying parts list will give part number, description, assembly relationship and quantity required for that particular application.

(b) When the part number is not known:

- 1 Look through the illustrations and find the assembly of which the component is part, or look through the illustrations and identify the part by appearance. Note the item number in the exploded view and find part, description and quantity required for that part.

**Lou Martin & Assoc., Inc.**  
Component Maintenance Manual

(5) List of abbreviations

The following abbreviations have been used in this CMM:

AR	As Required. Indicates that an indefinite quantity is required
ASSY	Assembly
CMM	Component Maintenance Manual
CAGE CODE	Commercial and Government Entity Code
DET	Detail
FIG	Figure
H	Horizontal
IND	Indenture
IPL	Illustrated Parts List
LH	Left Hand
NHA	Next Higher Assembly
NP	After any description means that this part number constitutes an assembly of breakdown parts not supplied as a whole. Although not procurable, a view of each assembly, sub-assembly, sub-sub-assembly, or small unit, exploded as necessary to show detail parts, is provided to illustrate each part in the detail parts list. Illustrations of all parts will be technically correct in assembly installation relation ships.
QTY	Quantity
RF	Reference indicates those parts which have their quantity listed elsewhere in the Illustrated Parts List.
R	Recline
RH	Right Hand
SYM	Symmetrical
V	Vertical

INTRO IPL  
PAGE 5  
MAY 08/06

**Lou Martin & Assoc., Inc.**  
Component Maintenance Manual

PAGE INTENTIONALLY LEFT BLANK

INTRO IPL  
PAGE 6  
MAY 08/06

25-23-11

**Lou Martin & Assoc., Inc.**  
Component Maintenance Manual

3. Alphanumerical index

PART NUMBER	AIRLINE STOCK NUMBER	FIGURE	ITEM	TTL REQUIRED
00-113M004-11		09	90	2
00-113M005-3/-4 (OPP)		09	80	2
00-113M014-1		09	30	1
2024-T3511 ALUM.		09	10, 60	3
875-XXX		09	40	A/R
P180-113M001-1		08	040	1
P180-113M002-7		09	20	1
P180-113002-59		08	020	1
P180-113M002-51		08	030	1
P180-113M002-5		08	010	2

ALPHANUMERICAL INDEX  
PAGE 1  
MAY 08/06

**Lou Martin & Assoc., Inc.**  
Component Maintenance Manual

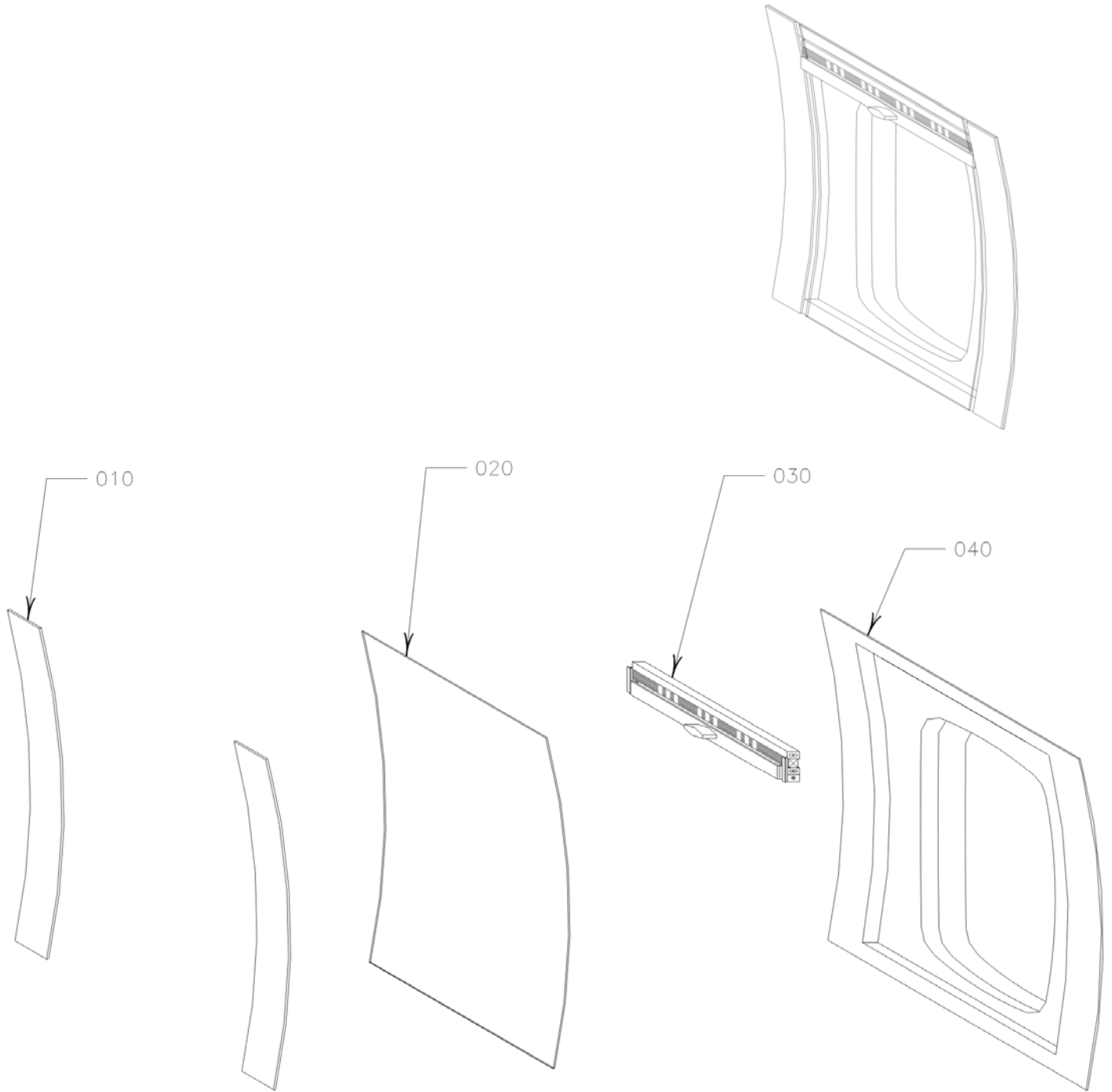

Decorative Window Shade Assy.  
FIGURE 8/ GRAPHIC 25-23-11-991-008

**Lou Martin & Assoc., Inc.**  
Component Maintenance Manual

8 FIG-ITEM	PART NUMBER	AIRLINE PART NUMBER	I N D	NOMENCLATURE	USAGE FROM TO	UNITS PER ASSY.
010	P180-113M002-5		1	SLIDE TRACK ASSY.		2
020	P180-113M002-59		1	INNER LENS		1
030	P180-113M002-51		1	BLIND MOD. (MECH)		1
040	P180-113M002-1		1	WINDOW REVEAL		1

**Lou Martin & Assoc., Inc.**  
Component Maintenance Manual

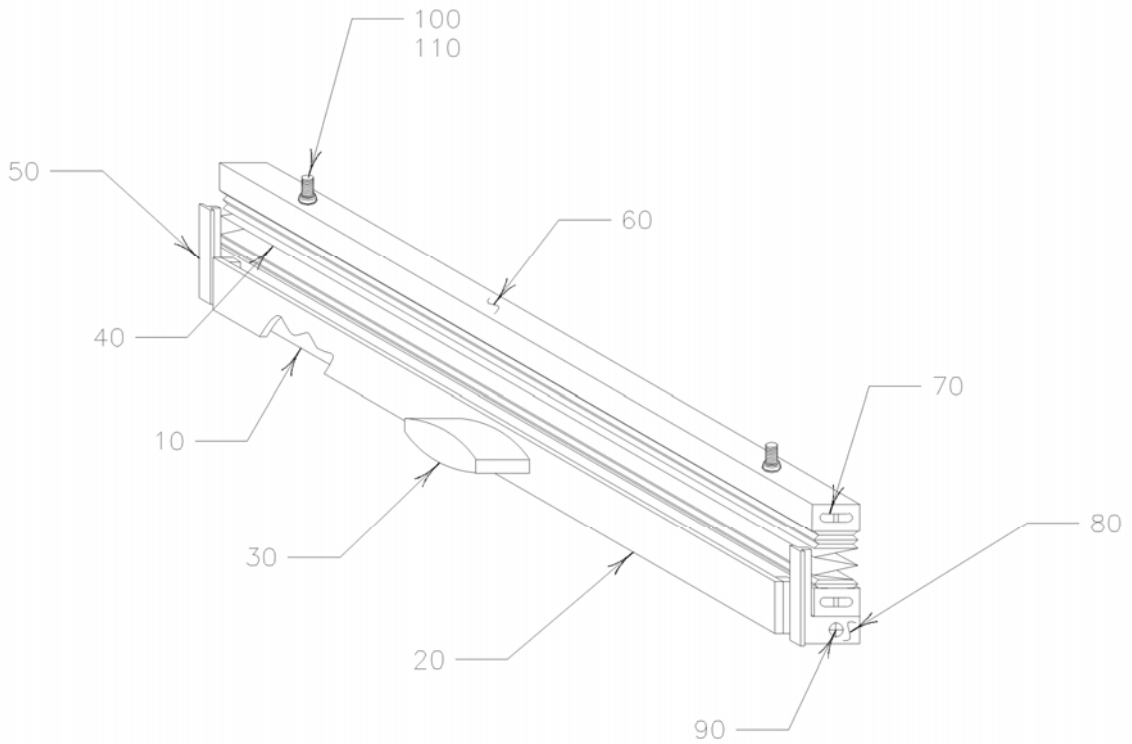
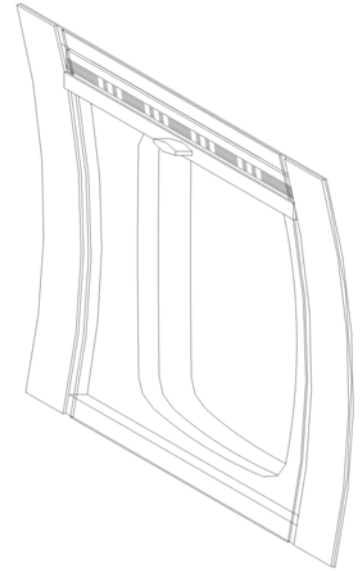

Blind Mod. Assy.  
FIGURE 9/ GRAPHIC 25-23-11-991-009

**Lou Martin & Assoc., Inc.**  
Component Maintenance Manual

9 FIG-ITEM	PART MUMBER	AIRLINE PART NUMBER	I N D	NOMENCLATURE	USAGE FROM TO	UNITS PER ASSY.
10	2024-T3511 ALUM.		1	LOWER RAIL		2
20	P180-113M002-7		1	HANDLE ASSY.		1
30	00-113M014-1		1	GRAB HANDLE		1
40	875-XXX		1	SHADE FABRIC		A/R
50	00-113M005-3		1	GLIDE		1
60	2024-T3511 ALUM.		1	TOP RAIL		1
70			1	END CAP		4
80	00-113M005-4 (OPP)		1	GLIDE (OPP)		1
90	00-113M004-11		1	DELRIN BLOCK		2
100	MS24693S-632		1	SCREW		A/R
110	MS21055-N06		1	STOP NUT		A/R